

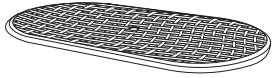

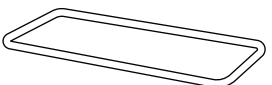

Parts & Hardware

A		x 1
B		x 1
C		x 4 PC
D		x 4 Screw Set 8 x 35mm
E		x 8 Screw Set 6 x 40mm

Garden Trading®

Marcham Oval 6 Seater Dining Set Assembly Instructions

Please check that you have all the parts listed before discarding any packaging.

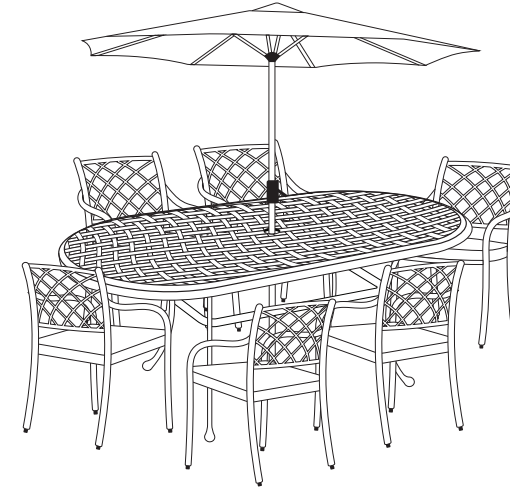

Settling in: A Guide To Your New Furniture

IMPORTANT

- For ease of assembly, we advise that two people work together, as parts can be heavy.
- Assemble your new furniture on a non-abrasive surface, such as a dust sheet or the original cardboard packaging.

1. PREPARATION

- Clear a large, flat area for assembly.
- Unbox all parts and check against the provided parts list.

2. ASSEMBLY

- Ensure that all screws and fittings are loosely attached before tightening.
- We advise using only hand tools. Power tools can damage your new furniture.
- Avoid over-tightening screws, as this can lead to damage.

3. HANDLING

- To prolong the life of this furniture set's parasol, avoid leaving it open and unattended. Always close and remove it when not in use or during adverse weather. Ensure the canopy is dry before closing and covering with a parasol cover. When not in use for extended periods, store the parasol in a dry, well-ventilated indoor space.
- To move your new furniture, always lift it. To avoid breakages, do not drag pieces across the floor.

4. CARE

- To maintain the condition of your furniture, avoid using abrasive or corrosive cleaning agents.
- We suggest using a garden furniture cover when your furniture is not in use to keep it clean and protected.

Garden Trading®

gardentrading.co.uk

customerservices@gardentrading.co.uk

TGTC, Hargreaves Road, Groundwell Industrial Estate, Swindon, SN25 5AZ

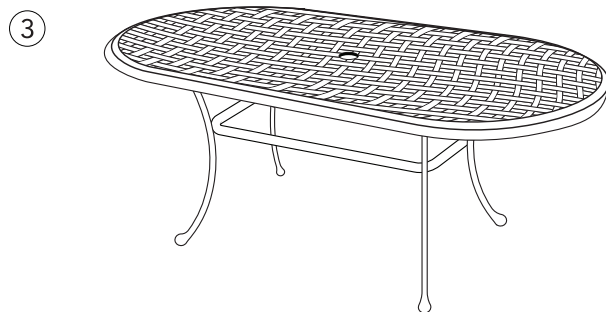
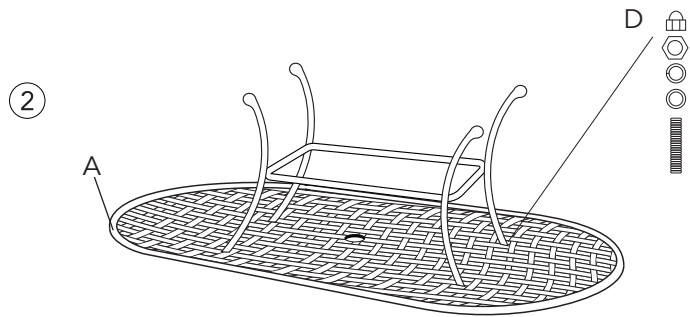
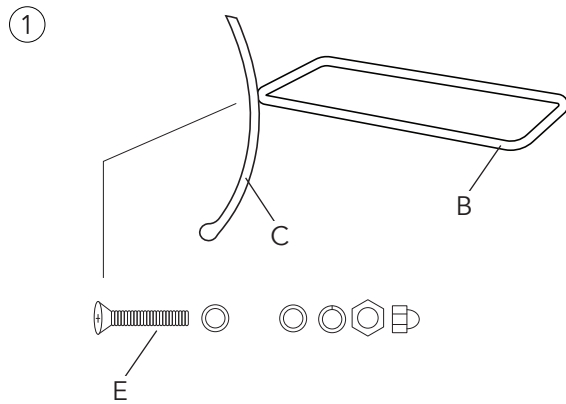
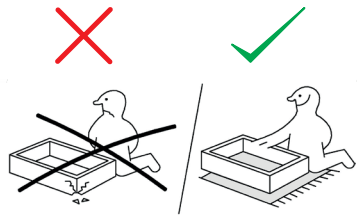

Assembly Guidance

1. Prepare Your Workspace: To protect the finish of your new furniture, assemble the set on a clean, soft surface such as a piece of carpet or a blanket.
2. Unpack with Care: Upon arrival, carefully remove all packaging materials. Take care when removing packaging to avoid damaging the surfaces of your furniture.
3. Check All Parts: Before assembly, ensure all parts are accounted for by checking them against the provided parts list.
4. Gentle Tightening Required: Please avoid over-tightening screws or bolts, as aluminium is a soft metal. Over-tightening can strip threads or break parts.
5. Step-by-Step Assembly: Begin by finger-tightening all nuts, then use a spanner or socket for the final tightening to complete the assembly securely.

IMPORTANT: DO NOT USE A DRILL DURING ASSEMBLY.

Step 1: Assemble the Legs

- Insert the studs with a washer (E) into the legs (C) using a screwdriver.
- Attach the Centre Plate (B) to the legs (C), then fit the washer (E), lock washer (E), and nut (E).
- Hand-tighten the nuts only at this stage.

Step 2: Attach the Tabletop

- Place the Tabletop (A) face down on a soft, flat surface to avoid scratches.
- Insert the screws (D) into the pre-drilled holes and tighten using a screwdriver.
- Attach the legs (C) to the Tabletop (A), and fit the washer (D), lock washer (D), and nut (D). Hand-tighten the nuts.

Step 3: Final Tightening

- Once all parts are assembled, use a spanner to tighten all nuts, being careful not to over-tighten.
- Finally, attach the plastic caps.

Levelling Your Table

- Your table is now ready for use. If needed, adjust the plastic feet to ensure the table is level.

Furniture Care Advice

FURNITURE CUSHIONS

- Storage: During extended periods of non-use or adverse weather conditions, store your furniture cushions in a dry and well-ventilated indoor space. Ensure all cushions are clean and completely dry before storage.
- Inspection: Regularly check cushions for signs of mould, mildew, or damage from animals.
- Spillage Management: Address any spills immediately using an absorbent sponge or cloth to prevent staining.

